

CASE I INLET TRANSITION STRUCTURE SECTION

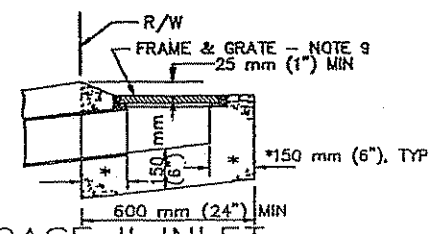

CASE II INLET DROP INLET CATCH BASIN SECTION

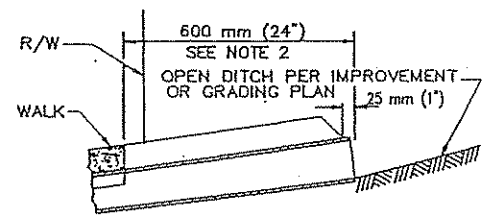

CASE III INLET GRADED DITCH SECTION

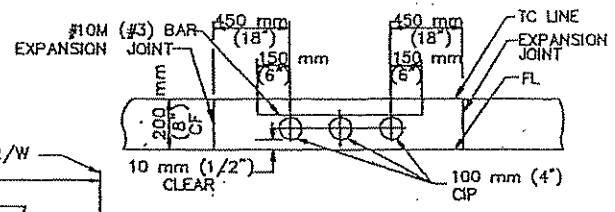
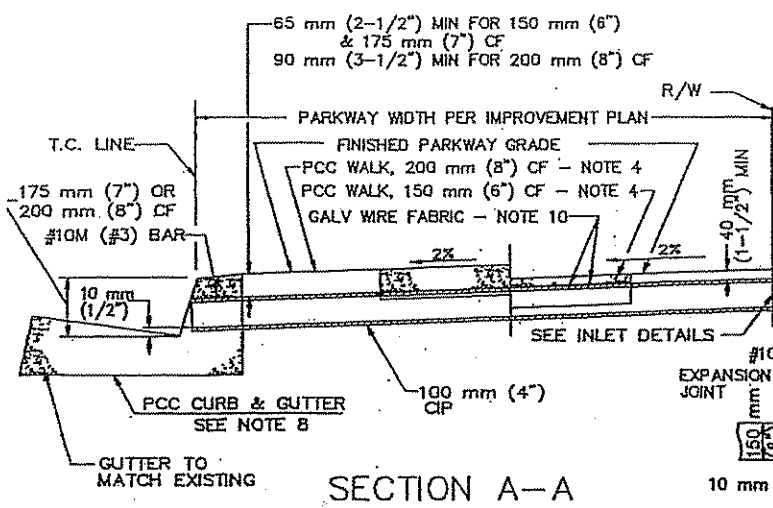

NOTE: APPLIES TO ANY NUMBER OF PIPES
CURB PROFILE
200 mm (8") CURB FACE

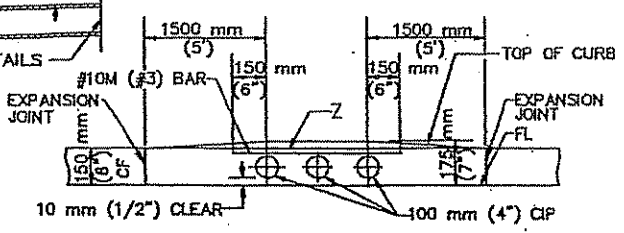

NOTE: APPLIES TO ANY NUMBER OF PIPES
Z = TOP-OF-CURB LINE SHOWN ON PROFILE
CURB PROFILE
150 mm (6") CURB FACE

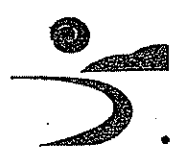

City of Santa Monica
Department of Public Works

1437 4th Street, Suite 300 Santa Monica, CA 90401
TEL (310) 458-8721 FAX (310) 393-4425
e-mail: smengineering@smgov.net

STANDARD CURB DRAIN

SUBMITTED BY :	DATE : 3-18-2010	DRAWING NO.
APPROVED BY : <i>[Signature]</i>		SM 10
Director of Public Works / City Engineer		1 of 1