

SEWER NOTES

1. THE SEWER FACILITIES TO BE DEDICATED TO THE CITY OF SANTA MONICA SHALL BE CONSTRUCTED IN ACCORDANCE WITH THE STANDARD SPECIFICATIONS OF THE CITY OF SANTA MONICA.
2. THE CITY SHALL BE NOTIFIED AT LEAST FOURTEEN (14) WORKING DAYS PRIOR TO START OF CONSTRUCTION AT CITY HALL'S PUBLIC WORKS COUNTER.
3. THE MANHOLE FRAME AND COVER AND CONCRETE SUPPORT FOR MANHOLES SHALL BE RAISED AND CONSTRUCTED TO FINISHED PAVED GRADE AFTER THE PAVING OPERATION IS COMPLETED. THE RING SECTION SHALL NOT BE MORE THAN 24" FROM THE CONE. THE COMPLETE SEWER SYSTEM SHALL BE COMPLETELY CLEAN PRIOR TO ACCEPTANCE.
4. WHERE THE MANHOLE STRUCTURE FALLS IN EXISTING PAVEMENT, TRAVELED WAY, OR SHOULDER, THE MANHOLE COVER SHALL BE PLACED FLUSH WITH THE EXISTING SURFACE. WHERE THE MANHOLE FALLS IN THE EXISTING ROADSIDE DITCH OR RIGHT-OF-WAY, OR IS CONSTRUCTED WITHIN AN EASEMENT, THE TOP SHALL BE PLACED APPROXIMATELY NINE (9) INCHES ABOVE EXISTING GROUND SURFACE AS DIRECTED BY THE ENGINEER, USING THE "ALTERNATE COLLAR" AS SHOWN ON DETAIL SS-8.
5. WORK SHALL BE DONE IN ACCORDANCE WITH SANTA MONICA ENCROACHMENT PERMITS OR SEWER PERMIT OR OTHER APPLICABLE PERMITS REQUIRED BY CITY OF SANTA MONICA PUBLIC WORKS COUNTER.
6. THE SEWER SYSTEM, INCLUDING LATERALS, SHALL BE HYDROSTATIC WATER OR AIR TESTED, AFTER ALL UNDERGROUND UTILITIES ARE CONSTRUCTED, AND PRIOR TO PLACING STREET PAVEMENT. CLEANING SHALL BE COMPLETED AFTER MANHOLES ARE ADJUSTED TO FINISH GRADE.
7. NEW SEWER LINES SHALL BE VIDEO'ED PRIOR TO STREET PAVING FOR ACCEPTANCE.
8. EXISTING SEWER LOCATION AND FLOW LINE SHALL BE VERIFIED IN THE FIELD BY THE CONTRACTOR BEFORE START OF CONSTRUCTION. THE CITY SHALL BE NOTIFIED IMMEDIATELY OF ANY DISCREPANCIES.
9. ONE COMPLETE SET OF AS-BUILT (RED LINED) DRAWINGS SHALL BE FURNISHED TO THE CITY ON COMPLETION OF CONSTRUCTION.
10. PRIOR TO COMMENCING WORK, CONTACT THE WATER RESOURCES DIVISION REPRESENTATIVE AT 310-458-8533. THE WASTE WATER INSPECTOR WILL INFORM THE APPLICANT OF ADDITIONAL REQUIREMENTS.
11. CALL WASTE WATER INSPECTOR FOR FINAL INSPECTION UPON COMPLETION.

DATE	NO.	REVISION / NOTE	BY
12-24-2014	-	ORIGINAL DRAWING ISSUED	AJS

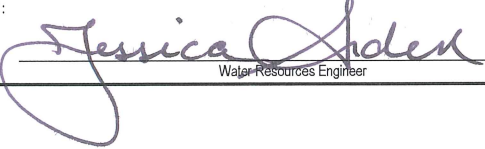

STANDARD SEWER NOTES

APPROVED BY:  Water Resources Engineer	DATE: 3/2015	DES: AJS D: SEM T: C:	SCALE: NONE DATE: 12-24-2014 APP:	SHEET NO. 1 OF 1 SS-1
---	--------------	--------------------------------	---	-------------------------------------

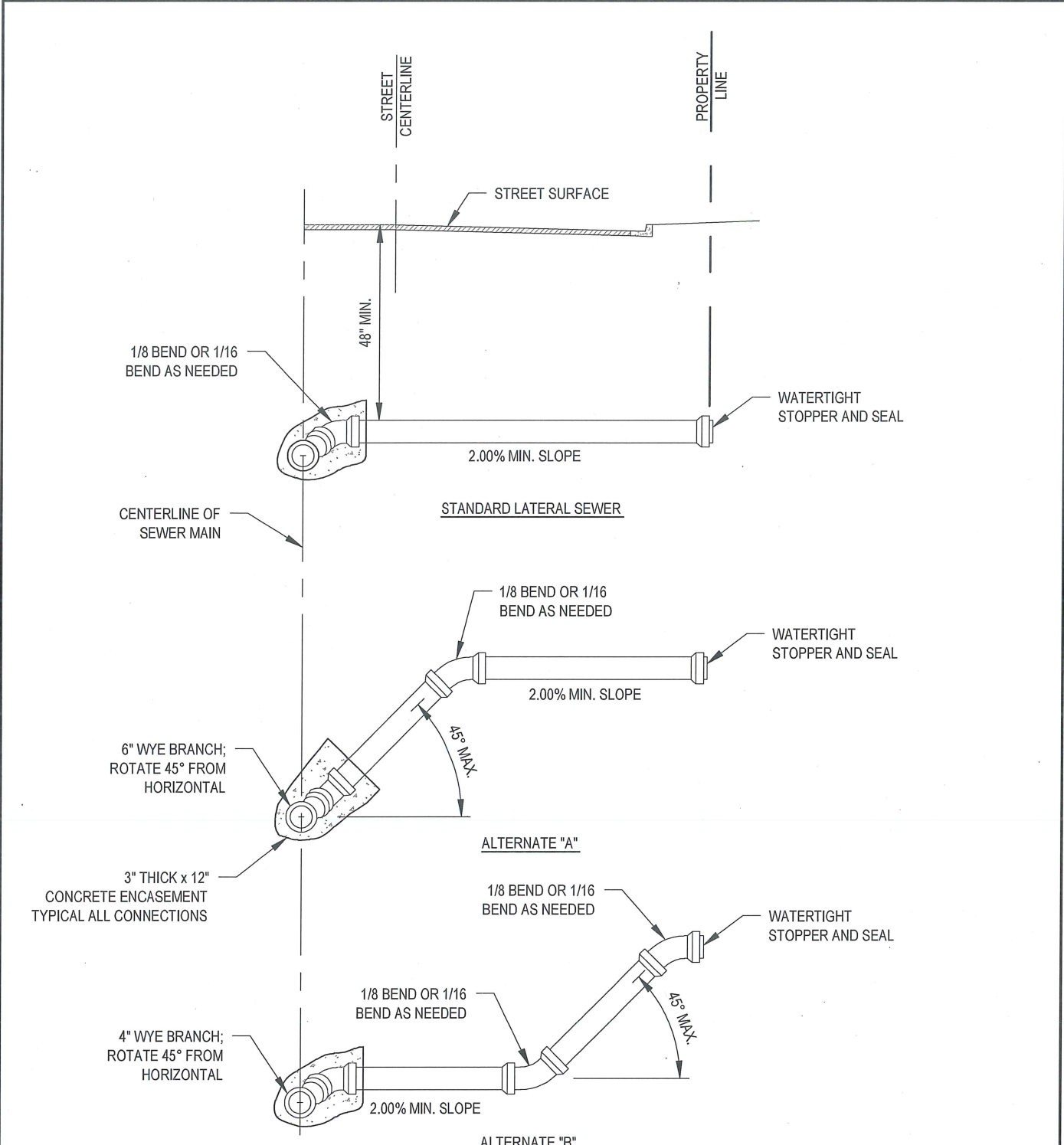

SEE DETAIL SS-3, "TYPICAL SEWER LATERAL" FOR FURTHER DETAILS.

City of Santa Monica
 Department of Public Works

LATERAL SEWER INSTALLATION

DES: AJS	SCALE: NONE	SHEET NO. 1 OF 1
D: SEM	DATE: 12-24-2014	SS-2
T:	APP:	
C:		

DATE	NO.	REVISION / NOTE	BY
12-24-2014	-	ORIGINAL DRAWING ISSUED	AJS

APPROVED BY: *Jessica Arden* DATE: 3/2015

Water Resources Engineer

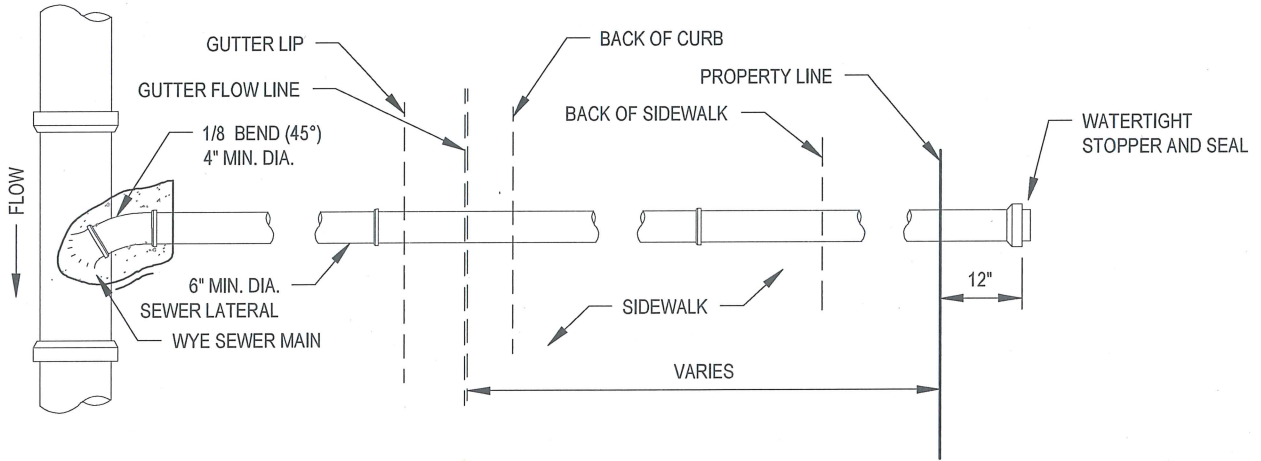

PLAN

A CITY PERMIT AND INSPECTION ARE REQUIRED FOR SEWER SERVICE AND INSTALLATION.

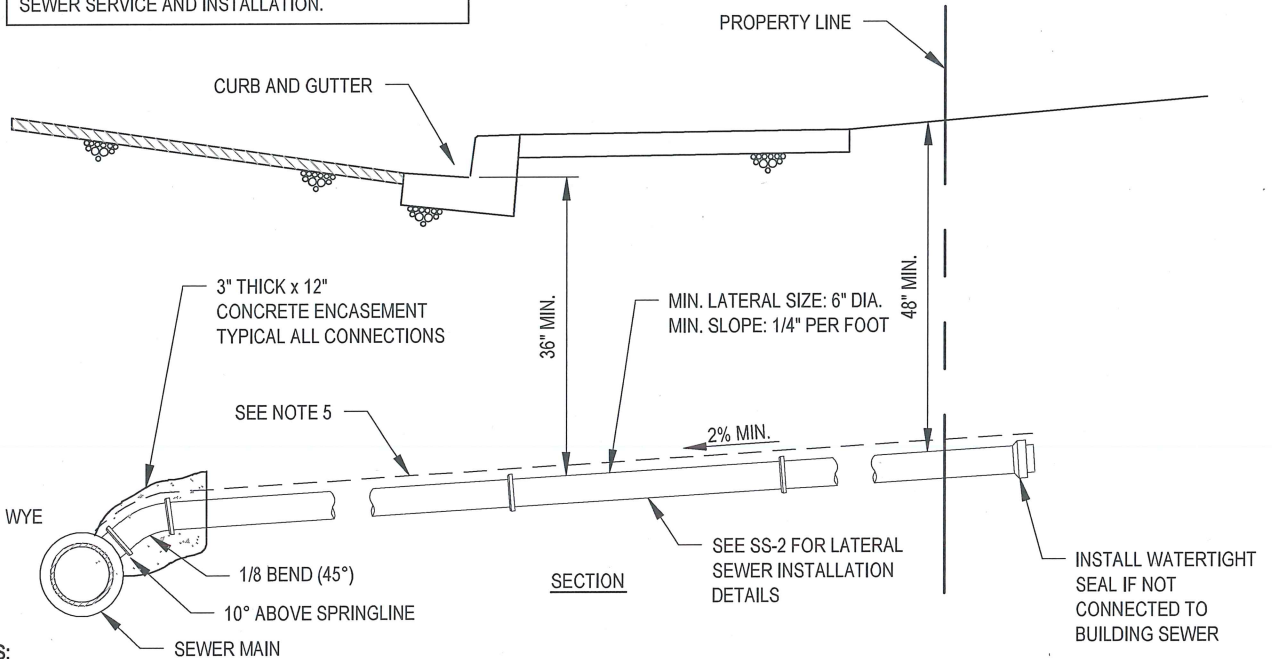

SECTION

NOTES:

1. LATERALS SHALL BE PVC PIPE AND ENCASED IN CONCRETE WHEN THE COVER IS LESS THAN 24" OVER THE TOP OF PIPE. OTHERWISE, LATERAL SHALL BE SDR 35 PVC.
2. MAINTAIN MINIMUM 10' HORIZONTAL SEPARATION FROM WATER SERVICE.
3. LATERAL SEWERS SHALL NOT BE LOCATED IN DRIVEWAYS UNLESS APPROVED BY THE CITY ENGINEER.
4. FOR LATERAL SEWERS CONNECTING ONTO EXISTING SEWER MAIN, A SEWER SADDLE SHALL BE USED.



TYPICAL SEWER LATERAL

DATE	NO.	REVISION / NOTE	BY
12-24-2014	-	ORIGINAL DRAWING ISSUED	AJS

APPROVED BY: *Jessica Arden*
 Water Resources Engineer

DATE: 3/20/15
 DES: AJS
 D: SEM
 T:
 C:

SCALE: NONE
 DATE: 12-24-2014
 APP:
 SHEET NO. 1 OF 1
SS-3

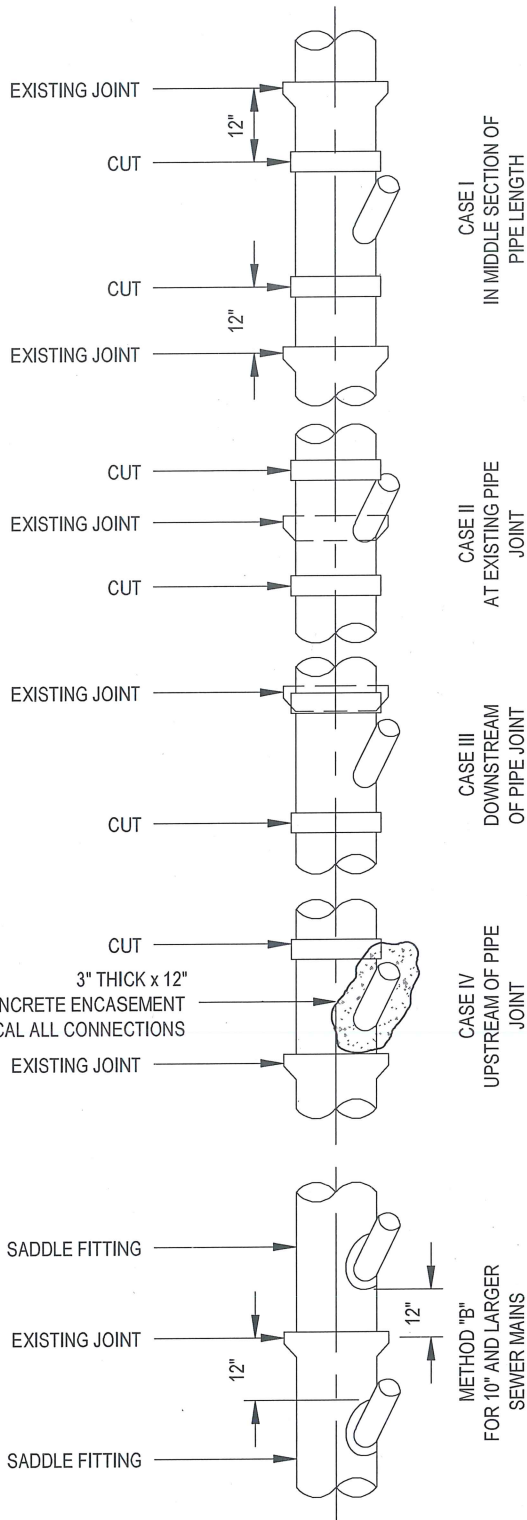

METHOD "A" AND SMALLER SEWER MAINS

INSTALLATION OF WYE BRANCH IN EXISTING SEWER MAIN

GENERAL:

1. METHOD "A" SHALL BE USED FOR ALL 8" SEWER MAINS. METHOD "B" MAY BE USED FOR 10" AND LARGER SEWER MAINS WHERE LOCATION OF HOUSE LATERAL PERMITS.
2. THE BRANCH FOR LATERAL SHALL BE 6" DIAMETER UNLESS OTHERWISE DIRECTED BY ENGINEER, AND MAY BE BELL AND SPIGOT TYPE OF AN APPROVED BAND COUPLING TYPE (BAND-SEAL OR EQUAL).
3. WYE BRANCH FITTINGS SHALL BE INSTALLED WITH THE BRANCH STUB AT AN ANGLE OF 45° UPWARD FROM THE HORIZONTAL.
4. IRREGULAR CUT ENDS, OVERSIZE OR RAGGED OPENINGS, PIPE CRACKED OR OTHERWISE DAMAGED BY CONTRACTOR SHALL REQUIRE REPLACEMENT AT THE CONTRACTOR'S EXPENSE.
5. WATER RESOURCES DIVISION WASTE WATER INSPECTOR MUST BE PRESENT DURING INSPECTION.

METHOD "A":

1. CUT AND REMOVE SECTION OF EXISTING PIPE. CUT ENDS SHALL BE SMOOTH AND SQUARE WITH PIPE.
2. A FACTORY FABRICATED BRANCH FITTING SHALL BE INSTALLED IN THE MAIN USING HEAVY DUTY RUBBER COUPLINGS WITH STAINLESS STEEL CLAMPS. COUPLINGS TO BE TYPE USED FOR SEWER REPAIRS (BAND-SEAL OR EQUAL).

METHOD "B":

1. THE CITY SHALL INSTALL ALL SADDLES ON MAIN. CONTRACTOR SHALL EXPOSE PIPE AND MAKE SPACE FOR ENTRY. CONTRACTOR SHALL FURNISH APPROVED SADDLE, SEALTITE SEWER SADDLE TYPE E, MODEL H, IRON BODY WITH STAINLESS STEEL BAND.

DATE	NO.	REVISION / NOTE	BY
12-24-2014	-	ORIGINAL DRAWING ISSUED	AJS



STANDARD WYE BRANCH INSTALLATION

APPROVED BY: *Jessica Aiden*
Water Resources Engineer

DATE: 3/20/15

DES: AJS
 D: SEM
 T:
 C:

SCALE: NONE
 DATE: 12-24-2014
 APP:

SHEET NO. 1 OF 1
 SS-4

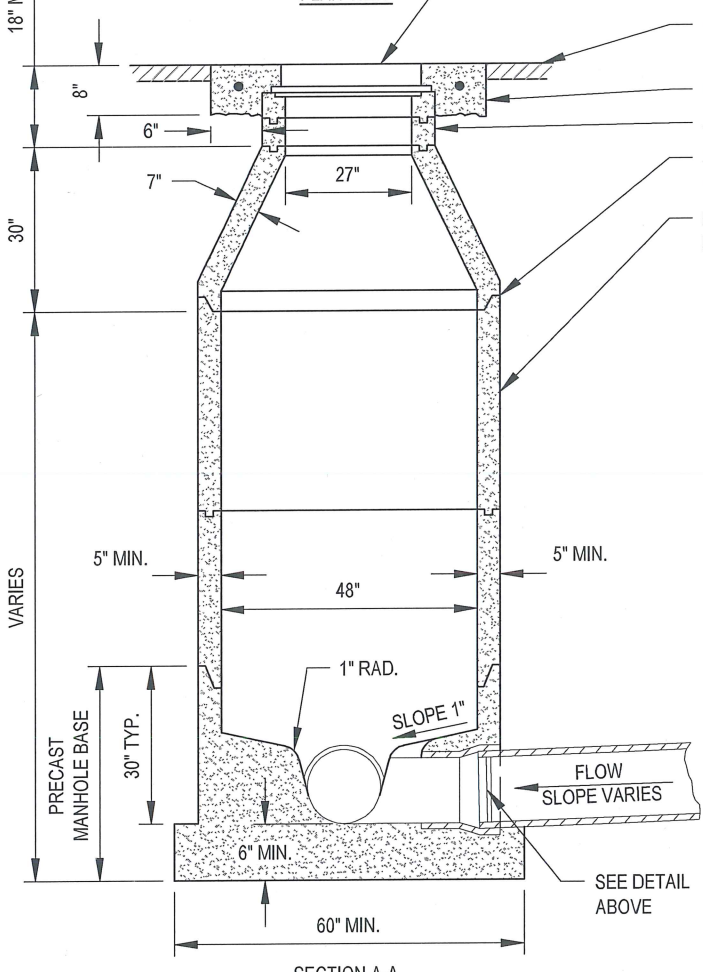
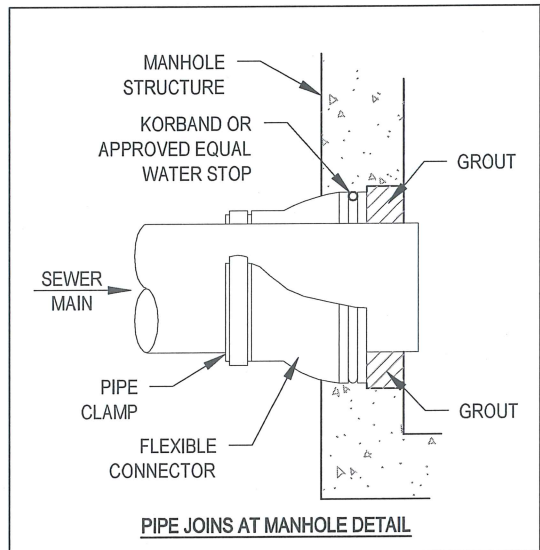
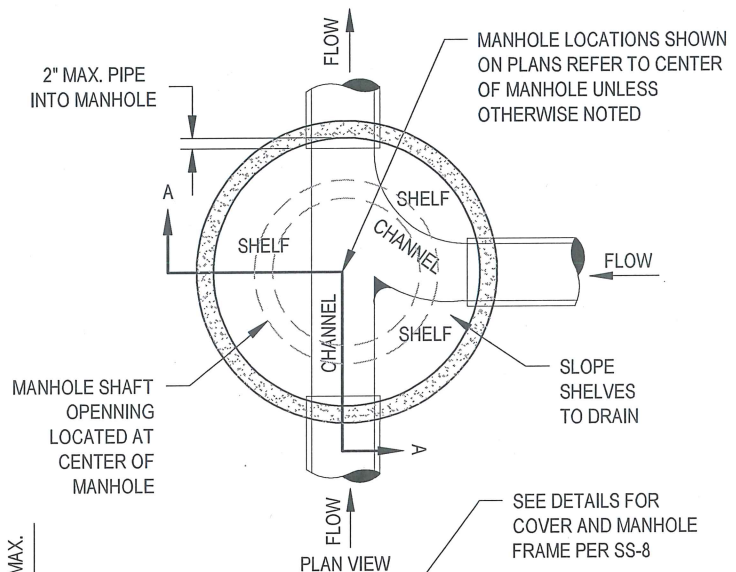

A.C. PAVEMENT
 CONCRETE COLLAR - CLASS A 6-SACK, 3000 PSI
 3" OR 6" RISER RINGS
 JOINTS TO BE SET IN A WATERTIGHT SEALANT, GROUTED INSIDE AND OUTSIDE.
 PRECAST CONCRETE (TYPICAL) MANHOLE WALLS SHALL BE A PRECAST TYPE CONFORMING TO ASTM STANDARD C479-61T FOR CLASS 2 REINFORCED CONCRETE PIPE.

- NOTES:**
1. MANHOLES SHALL BE WATERTIGHT.
 2. MANHOLES WITH A DEPTH GREATER THAN 10 FEET FROM COVER TO INVERT SHALL BE 60" DIAMETER STANDARD, SEE SS-7.
 3. BROKEN OR CHIPPED RINGS AND CONES SHALL NOT BE USED.
 4. MANHOLES MUST BE LINED BY MANUFACTURER WITH T-LOK.
 5. PRECAST REINFORCED MANHOLE BASES WITH IN-FLOW AND OUT-FLOW COUPLINGS SHALL BE CAST IN AT ENGINEERED INVERT, ANGLE AND SLOPE ELEVATIONS AT A 0.1' MIN. GRADIENT.
 6. THE CROWN ELEVATION OF ALL PIPES SHALL BE THE SAME AS THE CROWN ELEVATION OF THE LARGEST.
 7. CHANNELS SHALL BE SMOOTH WITH NO SHARP ANGLES OF PROJECTIONS. RADII OF CURVED CHANNELS SHALL BE AS LARGE AS POSSIBLE. WHERE PRACTICAL, THE CURVE SHALL BE TANGENT TO THE CHANNEL WITH WHICH IT CONNECTS.

City of Santa Monica
 Department of Public Works

48" I.D.
 STANDARD SEWER MANHOLE
 WITH PRECAST BASE

DES: AJS
 D: SEM
 T:
 C:

SCALE: NONE
 DATE: 12-24-2014
 APP:

SHEET NO. 1 OF 1
 SS-5

DATE	NO.	REVISION / NOTE	BY
12-24-2014	-	ORIGINAL DRAWING ISSUED	AJS

APPROVED BY: *Jessica Anderson*
 Water Resources Engineer

DATE: 3/3/2015

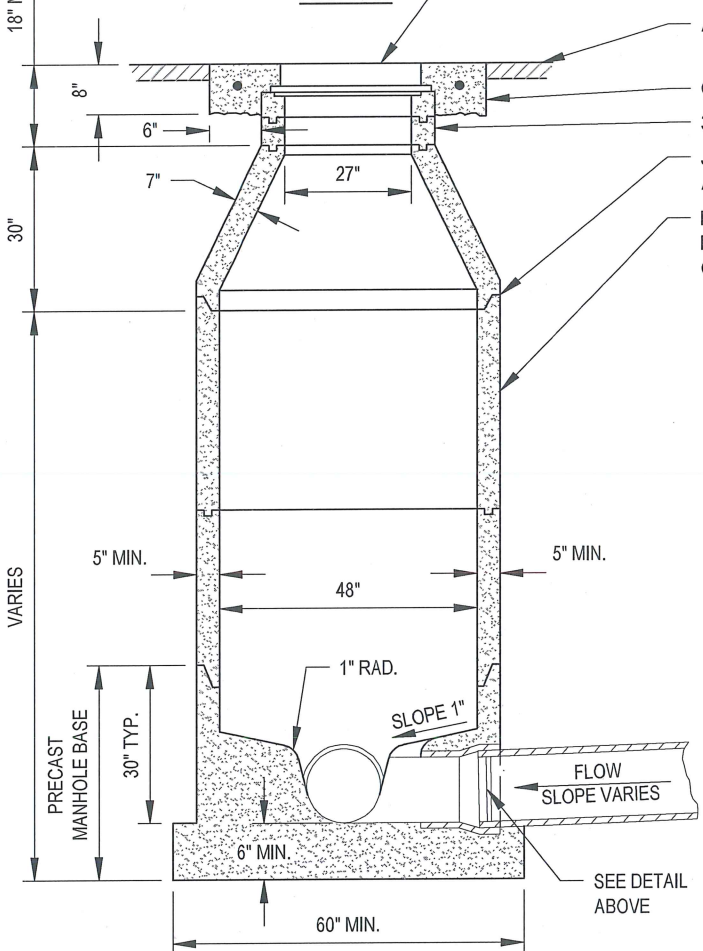
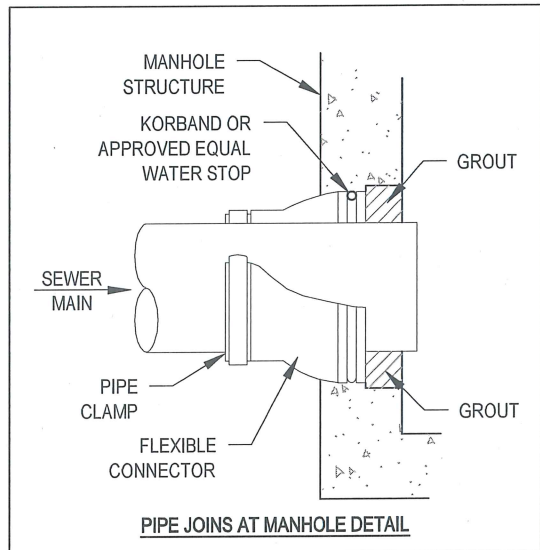
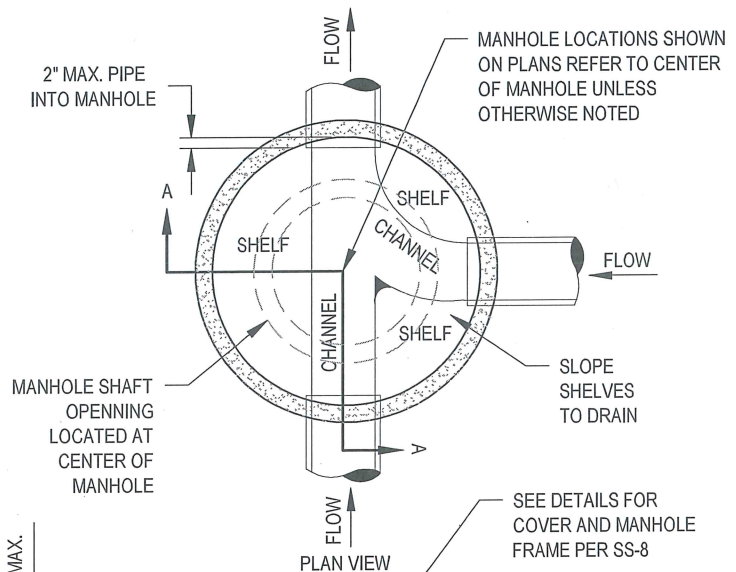

A.C. PAVEMENT
 CONCRETE COLLAR - CLASS A 6-SACK, 3000 PSI
 3" OR 6" RISER RINGS
 JOINTS TO BE SET IN A WATERTIGHT SEALANT, GROUTED INSIDE AND OUTSIDE.
 PRECAST CONCRETE (TYPICAL) MANHOLE WALLS SHALL BE A PRECAST TYPE CONFORMING TO ASTM STANDARD C479-61T FOR CLASS 2 REINFORCED CONCRETE PIPE.

NOTES:

1. MANHOLES SHALL BE WATERTIGHT.
2. MANHOLES WITH A DEPTH GREATER THAN 10 FEET FROM COVER TO INVERT SHALL BE 60" DIAMETER STANDARD, SEE SS-7.
3. BROKEN OR CHIPPED RINGS AND CONES SHALL NOT BE USED.
4. MANHOLES MUST BE LINED BY MANUFACTURER WITH T-LOK.
5. PRECAST REINFORCED MANHOLE BASES WITH IN-FLOW AND OUT-FLOW COUPLINGS SHALL BE CAST IN AT ENGINEERED INVERT, ANGLE AND SLOPE ELEVATIONS AT A 0.1' MIN. GRADIENT.
6. THE CROWN ELEVATION OF ALL PIPES SHALL BE THE SAME AS THE CROWN ELEVATION OF THE LARGEST.
7. CHANNELS SHALL BE SMOOTH WITH NO SHARP ANGLES OF PROJECTIONS. RADII OF CURVED CHANNELS SHALL BE AS LARGE AS POSSIBLE. WHERE PRACTICAL, THE CURVE SHALL BE TANGENT TO THE CHANNEL WITH WHICH IT CONNECTS.

City of Santa Monica
Department of Public Works

48" I.D.
STANDARD SEWER MANHOLE
WITH PRECAST BASE

DES: AJS	SCALE: NONE	SHEET NO. 1 OF 1
D: SEM	DATE: 12-24-2014	SS-5
T:	APP:	
C:		

DATE	NO.	REVISION / NOTE	BY
12-24-2014	-	ORIGINAL DRAWING ISSUED	AJS
APPROVED BY:		DATE: 3/15/15	DES: AJS
<p style="font-size: small; margin: 0;">Water Resources Engineer</p>			T: D: SEM
			C:

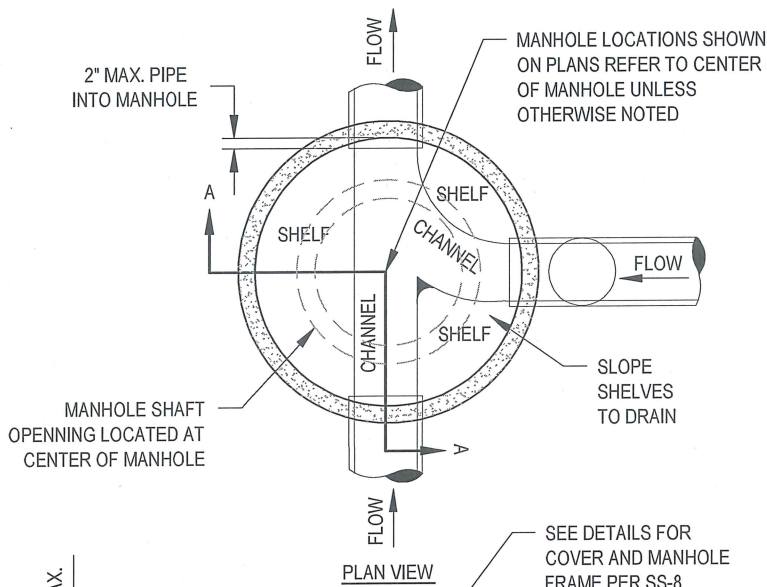

NOTES:

1. MANHOLES SHALL BE WATERTIGHT.
2. MANHOLES WITH A DEPTH GREATER THAN 10 FEET FROM COVER TO INVERT SHALL BE 60" DIAMETER STANDARD, SEE SS-7.
3. BROKEN OR CHIPPED RINGS AND CONES SHALL NOT BE USED.
4. MANHOLES MUST BE LINED BY MANUFACTURER WITH T-LOK.
5. PRECAST REINFORCED MANHOLE BASES WITH IN-FLOW AND OUT-FLOW COUPLINGS SHALL BE CAST IN AT ENGINEERED INVERT, ANGLE AND SLOPE ELEVATIONS AT A 0.1' MIN. GRADIENT.
6. THE CROWN ELEVATION OF ALL PIPES SHALL BE THE SAME AS THE CROWN ELEVATION OF THE LARGEST. CHANNELS SHALL BE SMOOTH WITH NO SHARP ANGLES OF PROJECTIONS. RADII OF CURVED CHANNELS SHALL BE AS LARGE AS POSSIBLE. WHERE PRACTICAL, THE CURVE SHALL BE TANGENT TO THE CHANNEL WITH WHICH IT CONNECTS.

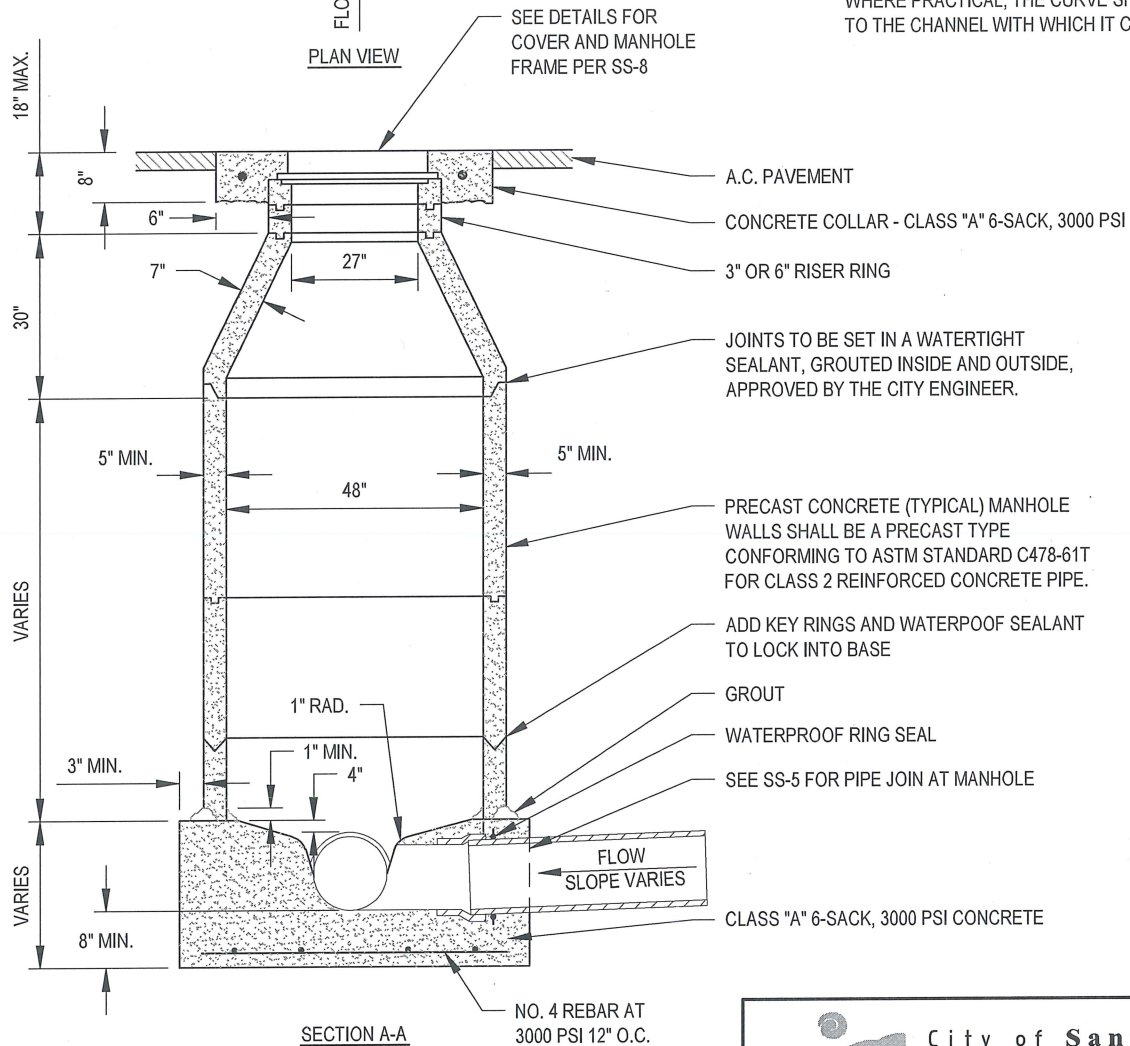

SECTION A-A

NO. 4 REBAR AT 3000 PSI 12" O.C.



48" I.D.
STANDARD SEWER MANHOLE
WITH CAST-IN-PLACE BASE

DATE	NO.	REVISION / NOTE	BY
12-24-2014	-	ORIGINAL DRAWING ISSUED	AJS

APPROVED BY:

Jessica Arden
Water Resources Engineer

DATE: 3/20/15

DES: AJS
D: SEM
T:
C:

SCALE: NONE
DATE: 12-24-2014
APP:

SHEET NO. 1 OF 1

SS-6

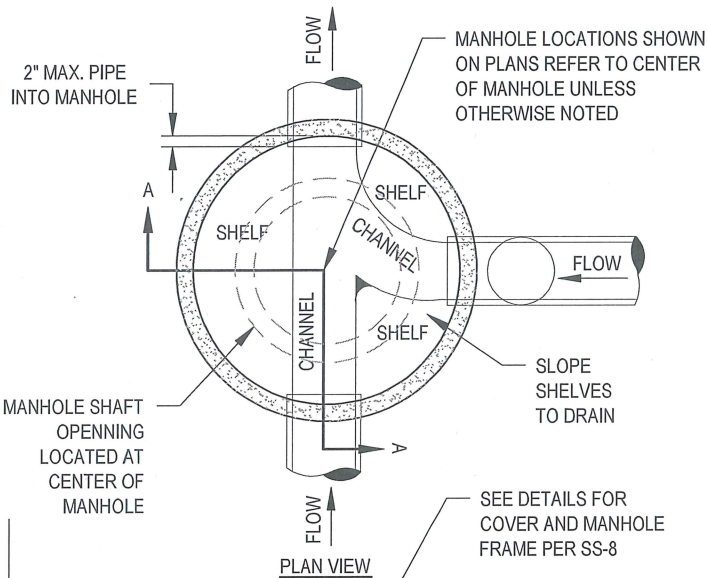

NOTES:

1. MANHOLES SHALL BE WATERTIGHT.
2. MANHOLES WITH A DEPTH GREATER THAN 10 FEET FROM COVER TO INVERT SHALL BE 60" DIAMETER STANDARD.
3. BROKEN OR CHIPPED RINGS AND CONES SHALL NOT BE USED.
4. MANHOLES MUST BE LINED BY MANUFACTURER WITH T-LOK.
5. PRECAST REINFORCED MANHOLE BASES WITH IN-FLOW AND OUT-FLOW COUPLINGS SHALL BE CAST IN AT ENGINEERED INVERT, ANGLE AND SLOPE ELEVATIONS AT A 0.1' MIN. GRADIENT.
6. THE CROWN ELEVATION OF ALL PIPES SHALL BE THE SAME AS THE CROWN ELEVATION OF THE LARGEST.
7. CHANNELS SHALL BE SMOOTH WITH NO SHARP ANGLES OF PROJECTIONS. RADII OF CURVED CHANNELS SHALL BE AS LARGE AS POSSIBLE. WHERE PRACTICAL, THE CURVE SHALL BE TANGENT TO THE CHANNEL WITH WHICH IT CONNECTS.

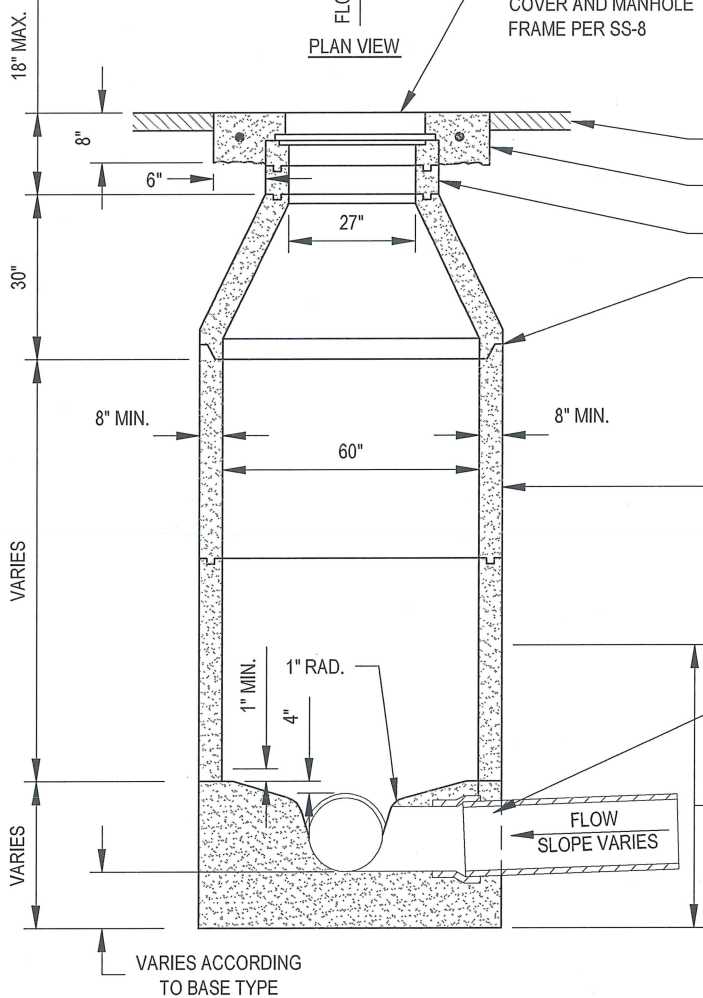

- A.C. PAVEMENT
- CONCRETE COLLAR - CLASS "A" 6-SACK, 3000 PSI
- 3" OR 6" RISER RING
- JOINTS TO BE SET IN A WATERTIGHT SEALANT, GROUTED INSIDE AND OUTSIDE, APPROVED BY THE CITY ENGINEER.
- PRECAST CONCRETE (TYPICAL) MANHOLE WALLS SHALL BE A PRECAST TYPE CONFORMING TO ASTM STANDARD C478-61T FOR CLASS 2 REINFORCED CONCRETE PIPE.
- SEE SS-5 FOR PIPE JOIN AT MANHOLE
- BASE DIMENSIONS VARY, SEE SS-5 FOR PRECAST BASE DETAIL, AND SEE SS-6 FOR CAST-IN-PLACE DETAIL

SECTION A-A

DATE	NO.	REVISION / NOTE	BY
12-24-2014	-	ORIGINAL DRAWING ISSUED	AJS



City of Santa Monica
Department of Public Works

60" I.D.
STANDARD SEWER MANHOLE

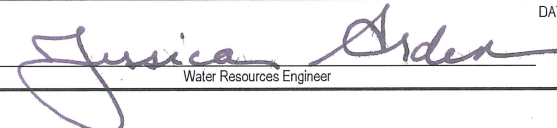
APPROVED BY:	DATE: 3/2015	SHEET NO. 1 OF 1
 Water Resources Engineer	DES: AJS D: SEM T: C:	SCALE: NONE DATE: 12-24-2014 APP:
		SS-7

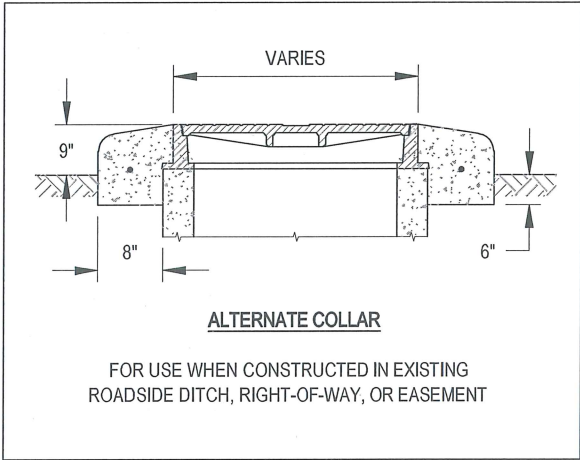
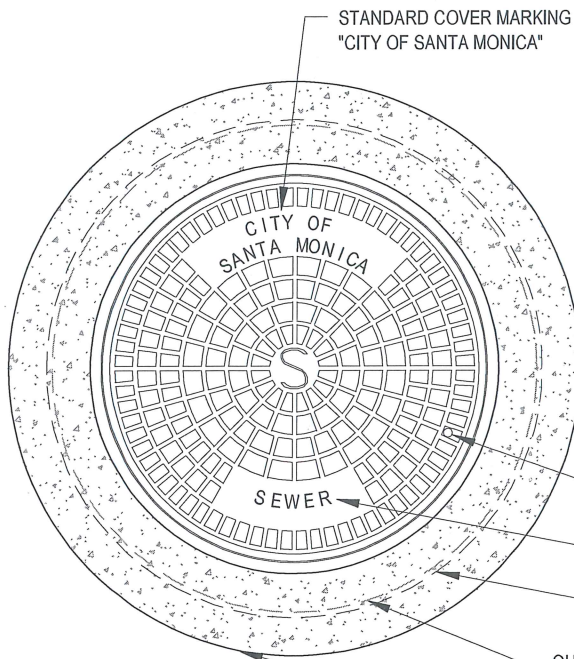

CONCRETE COLLAR:
 CLASS "A" 6-SACK, 3000 PSI, 3/4" AGG.
 8" THICK CONCRETE WITH 6" CLASS II AGG. BASE

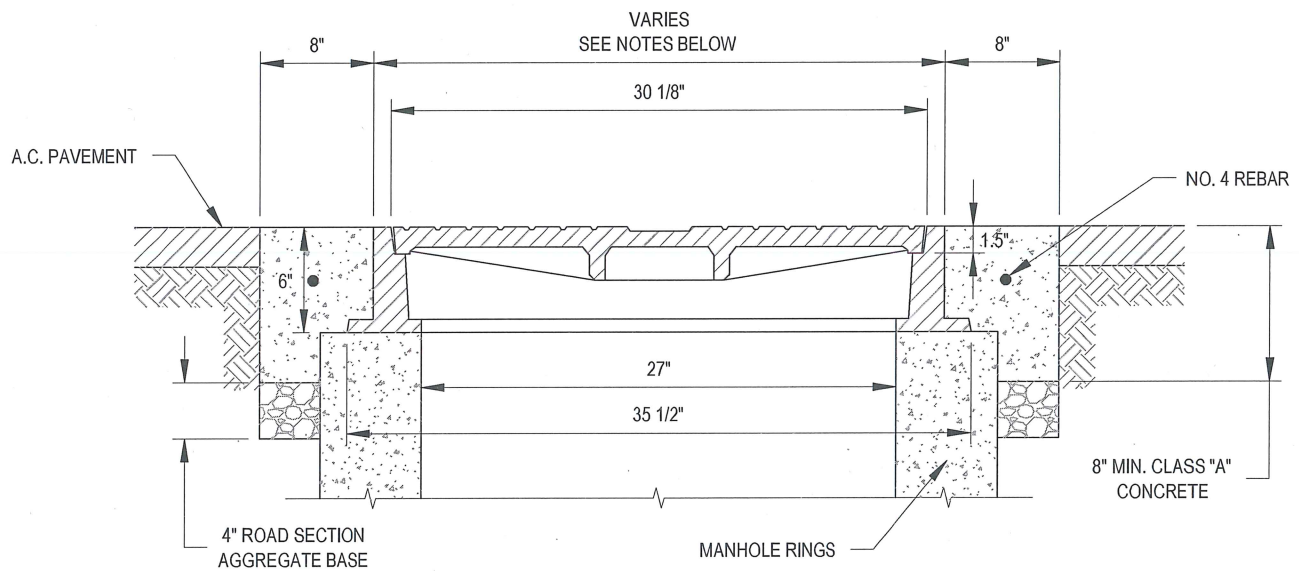

- NOTES:**
1. FOR 27" DIAMETER COVER, USE ALHAMBRA FOUNDRY NO. A-1496-C/R.
 2. ALL CONTACT SURFACES TO BE MACHINED.
 3. A HIGH TRAFFIC COVER MAY BE REQUIRED IN AREAS AS DETERMINED BY CITY ENGINEER.



City of Santa Monica
 Department of Public Works

MANHOLE FRAME AND COVER

APPROVED BY:	DATE: 3/20/15	DES: AJS D: SEM T: C:	SCALE: NONE DATE: 12-24-2014 APP:	SHEET NO. 1 OF 1 SS-8
--------------	---------------	--------------------------------	---	---------------------------------

DATE	NO.	REVISION / NOTE	BY
12-24-2014	-	ORIGINAL DRAWING ISSUED	AJS

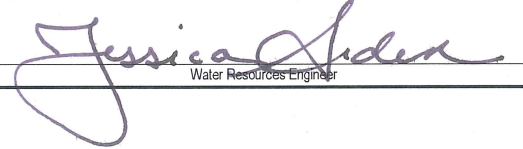
 Water Resources Engineer

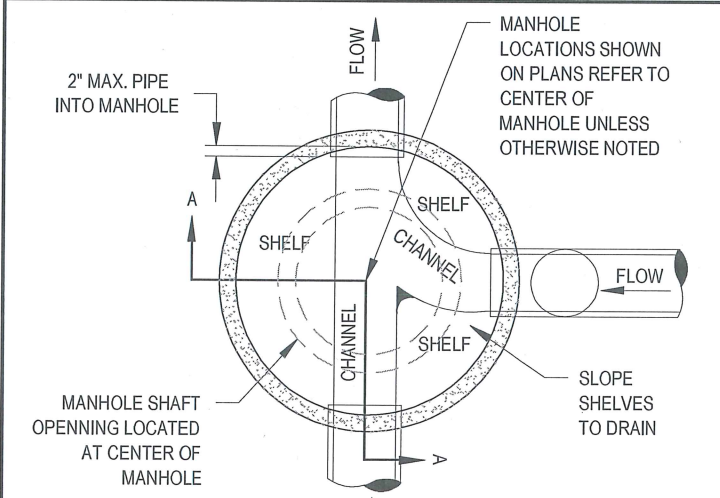

NOTES:

1. A DROP MANHOLE SHALL BE USED WHEN SEWER MAIN IS MORE THAN 12" ABOVE THE MANHOLE BOTTOM.
2. FOR SEWER MAINS LESS THAN 12" ABOVE THE MANHOLE BOTTOM, A CONCRETE TROUGH SHALL BE INSTALLED TO INSURE SMOOTH TRANSITION FROM PIPE TO MANHOLE.
3. MANHOLES SHALL BE WATERTIGHT.
4. BROKEN OR CHIPPED RINGS AND CONES SHALL NOT BE USED.
5. MANHOLES MUST BE LINED BY MANUFACTURER WITH T-LOK.
6. PRECAST REINFORCED MANHOLE BASES WITH IN-FLOW AND OUT-FLOW COUPLINGS SHALL BE CAST IN AT ENGINEERED INVERT, ANGLE AND SLOPE ELEVATIONS AT A 0.1' MIN. GRADIENT.
7. THE CROWN ELEVATION OF ALL PIPES SHALL BE THE SAME AS THE CROWN ELEVATION OF THE LARGEST.
8. CHANNELS SHALL BE SMOOTH WITH NO SHARP ANGLES OR PROJECTIONS. RADII OF CURVED CHANNELS SHALL BE AS LARGE AS POSSIBLE. WHERE PRACTICAL, THE CURVE SHALL BE TANGENT TO THE CHANNEL WITH WHICH IT CONNECTS.

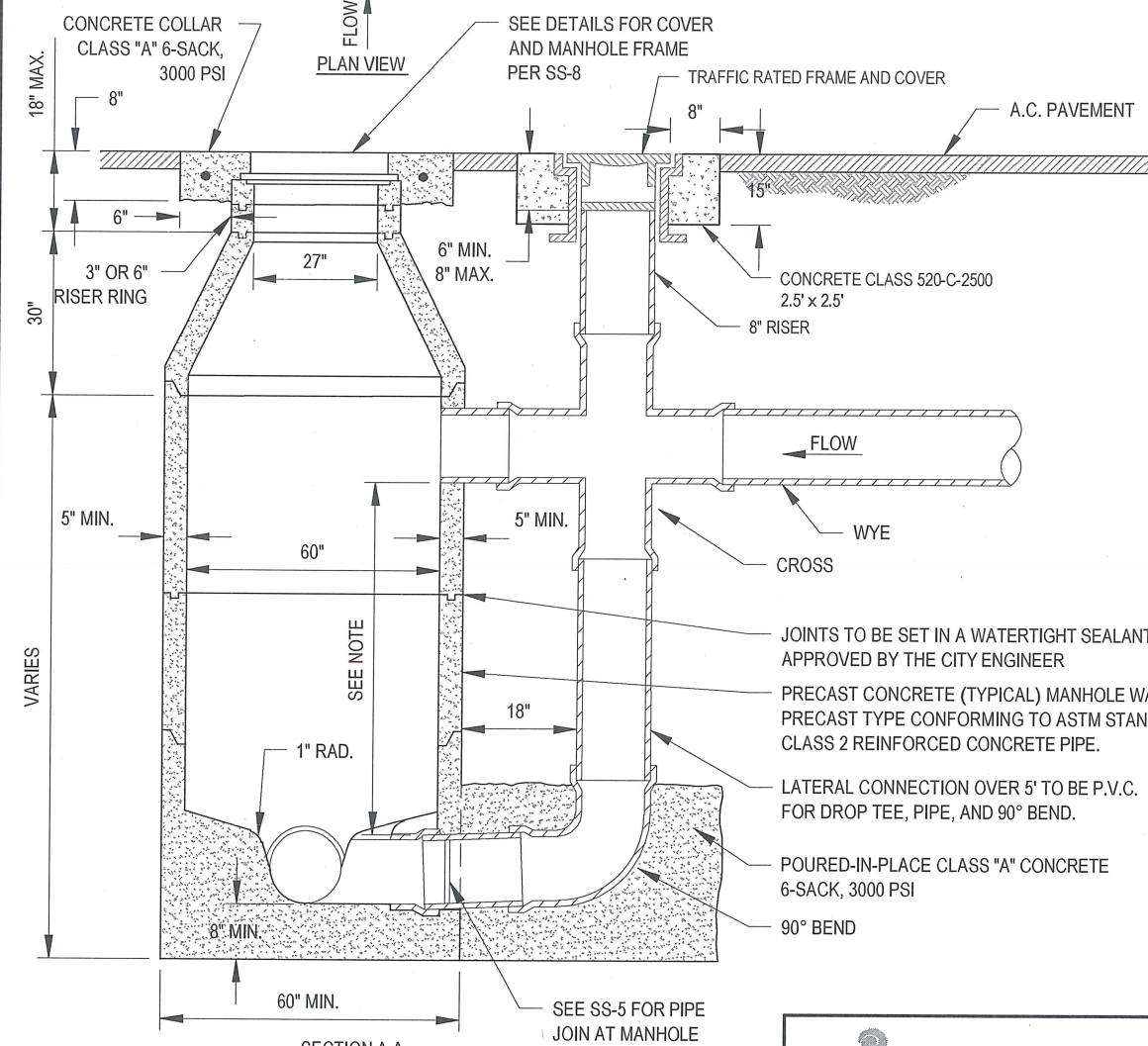

SECTION A-A



MANHOLE DROP INLET CONNECTION

DATE	NO.	REVISION / NOTE	BY
12-24-2014		ORIGINAL DRAWING ISSUED	AJS

APPROVED BY: *Jessica Arden*
 Water Resources Engineer

DATE: 3/20/15

DES: AJS
 D: SEM
 T:
 C:
 SCALE: NONE
 DATE: 12-24-2014
 APP:

SHEET NO. 1 OF 1
SS-9